

Maze-Orienteering

A race against the clock!

www.scoutOchallenge.com



A Leader's Guide to

Maze-O

A Fun Orienteering Activity

for

Scout Meetings

Kelly Atkinson
Orienteering@troop8787.org
Revision 2
19 Aug 2024

Maze-Orienteering

A race against the clock!
www.scoutOchallenge.com

What is Maze-O?

The Maze-O is a short, fun Orienteering course where the runners orient themselves on a map in a 40-ft square MAZE. They follow a course from point to point through the MAZE and punch/scan the markers at each control point. It's a fun race against the clock. There are several different difficulty levels that range from White (basic), to Yellow, Orange and Green (advanced). This is a fun activity for Scout meetings and introduces Scouts to Orienteering in a small, manageable area.

WHITE Course:

Follow the course from point to point until the finish. This is much like a traditional point-to-point course, only in a small maze.

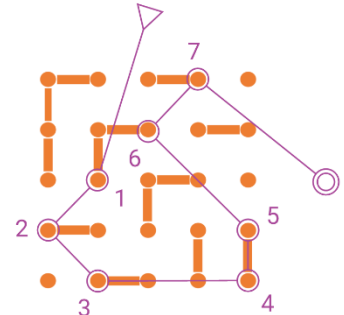

YELLOW Course:

Like the White course, however the course is NOT drawn on the map, follow the instructions to navigate from point to point using a list of Cardinal Directions (eg. go 2 South, then 2 East)

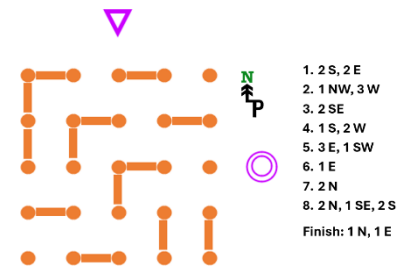

ORANGE Course:

The course becomes more difficult as you are given partial squares of the map to get from one control to the next.

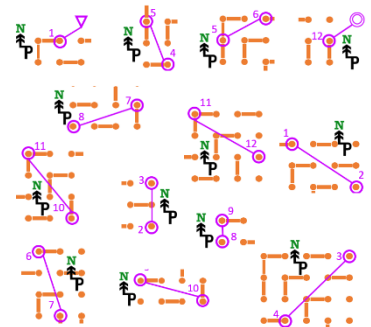

GREEN Course:

This map is shown in oddly cut shapes that show puzzle-like pieces of the map that are rotated off north. Find the piece that shows your current location and the next control and visit all of them as quickly as you can.

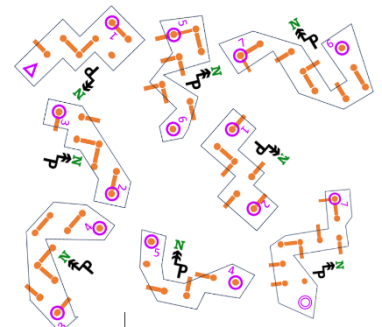

Maze-Orienteering

A race against the clock!

www.scoutOchallenge.com

Maze-O Set-up

The Maze is built on a 5x5 grid of garden stakes, cones, buckets, large rocks (or whatever you have), 10ft apart for a total of 40ft square (or whatever size you like). Some courses are sensitive to North (see the set-up diagram for North).

- Stake the first corner for the point with control code 111
- Connect a 100ft tape measure to the first stake, use a compass to align 101 stake due South
 - For best alignment, use a real compass, not your phone compass
- Install a stake every 10 ft
- Rotate tape measure from control 111 due East to control 115
- Install a stake every 10 ft
- Repeat 112 to 102, 113 to 103 etc until the entire grid is complete
- Tie neon construction tape or rope to make MAZE WALLS as shown in the diagram
 - the maze walls are not required; however they make the grid look more interesting and create some restriction of movement to the runners
- Install START (North of control 113) and FINISH stakes (East of control 116)
- Install control markers on each garden stake (clothespin a card to the stake, if you are using buckets or cones, just tape the markers...see Appendix)
 - Markers should display the control code (e.g “CC--125”) and include either a pin punch or a code for scouts to write down, or barcode if you are using scanners
 - If you would like to use a wireless barcode scanner, they are ~ \$30 on Amazon; email orienteering@troop8787.org for the free program used to record and score your runners on a PC. The Maze-O program is made to work with [Symcode 2D Wireless Barcode Scanner](#) and we usually run with 4 at a time. You could start with one.
- Set a table for your officials, NE of Control 115, convenient to start and finish makers

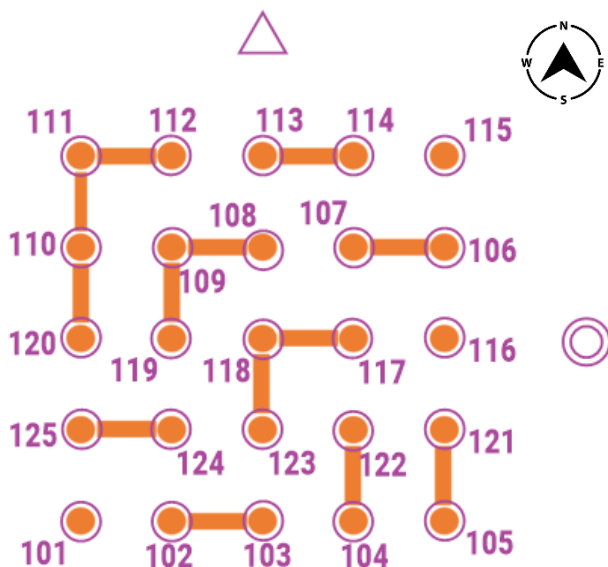

Maze-Orienteeing

A race against the clock!

www.scoutOchallenge.com

Maze-O Operation

Check-in table Supplies

- Table & chair for the Official(s)
- Maps (2-3 each course, in zip lock bags or laminated)
- If you are using punches or hand writing codes, you will need cards for runners to write codes or punch and the official needs a “key” to score each runner (see appendix)
- Timer, if you care (if using wireless barcode scanners, the program will keep time for you)
- If you are using a wireless barcode scanner, you need the scanner(s) and a PC to record results

At START:

- Provide instruction:
 - Choose the course to run, get a map
 - There are easy courses that follow a straightforward path through the maze
 - More difficult courses show partial sections of the maze
 - The most difficult courses show partial sections which are rotated off North
 - Explain that the runner will be following the map to visit markers in the maze in a race for the fastest time
 - Point out the Start and Finish Markers
 - If using wireless scanners:
 - the runner must clear scanner data and then scan the selected course (these are barcodes on the map)
 - Runner must scan the barcode at the Start Triangle to begin timer
 - Runner must scan the barcode at the Finish marker to stop timer
 - Runner must return the barcode scanner to get their time/score registered
- Provide the Map and record the start time

At FINISH:

- Record the finish time and score the runners card against the key (see appendix)
- If using barcode scanners (email me for scoring file):
 - take scanner from runner
 - make sure spreadsheet is in first column of next empty row
 - scan the “Upload Data” barcode
 - all the runner’s scans will transfer and be evaluated for time and correct scans
 - the Finish scan row will show total time and “OK” or “DQ”
 - duplicate scans are ignored; any scan missed or out of order will DQ runner
 - Type runner’s name on the FINISH row if they want to be listed on the leaderboard
 - There is a second tab in spreadsheet that summarizes top times by course (it refreshes every 2 minutes)
 - If you use your scoresheet in onedrive cloud, create a read-only link and use a QR code to let your participants watch the leader board on their phone

Maze-Orienteeing

A race against the clock!

www.scoutOchallenge.com

Maze-O

Courses

Print these for your orienteers to run the courses

Maze-Orienteering

A race against the clock!
www.scoutOchallenge.com

Start at the Triangle, visit each point circled on your course (in order).

Do NOT step over/under the maze walls (tape/rope)



1. Clear your scanner data
2. Scan your course selection
3. Scan at START TRIANGLE to start timer
4. **Run the course!**
5. Scan at FINISH sign to stop timer
6. Turn in your scanner to record your score/time

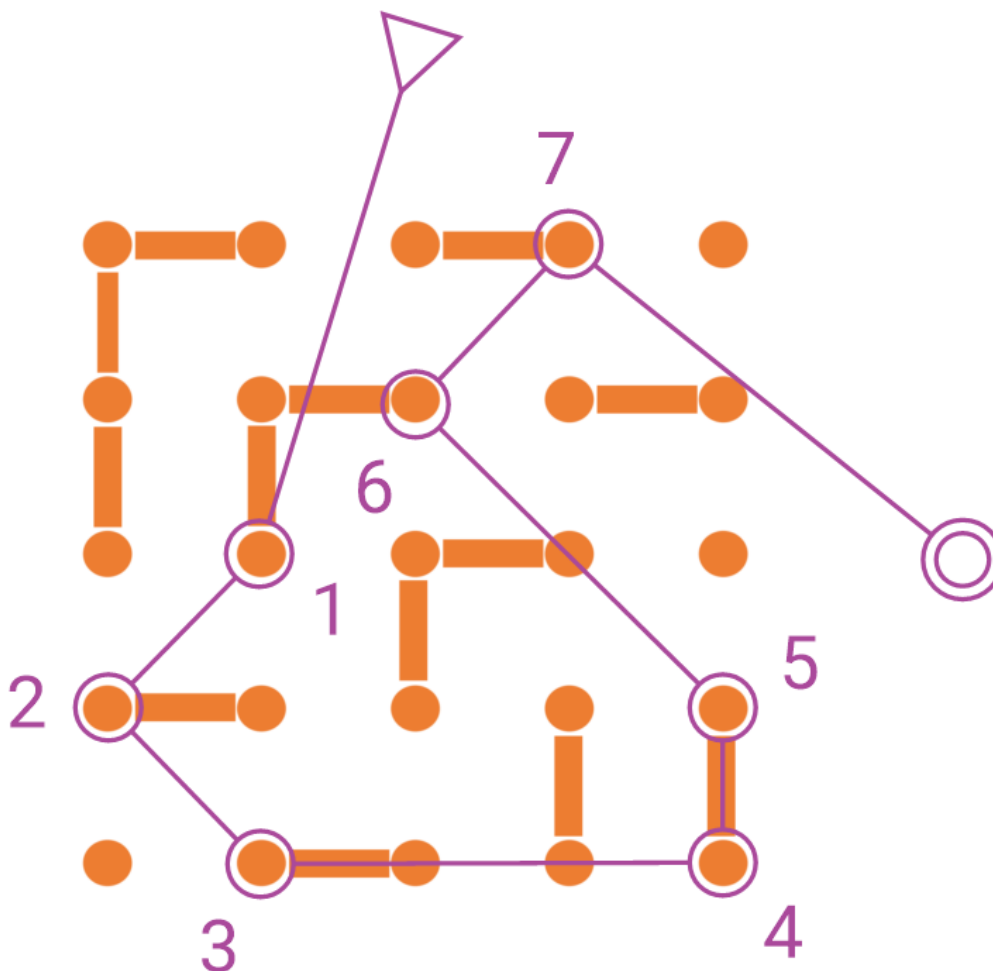

Clear Data

WHITE Course



	START--
1	CC--119
2	CC--125
3	CC--102
4	CC--105
5	CC--121
6	CC--108
7	CC--114
	FINISH-

Maze-Orienteeing

A race against the clock!
www.scoutOchallenge.com

Start at the Triangle and visit all control points in order, by using the list of cardinal directions (2 S, 2 E means go south 2 points and then east 2 points).

Do NOT step over/under the maze walls (tape/rope)

1. Clear your scanner data
2. Scan your course selection
3. Scan at START TRIANGLE to start timer
- 4. *Run the course!***
5. Scan at FINISH sign to stop timer
6. Turn in your scanner to record your score/time



Clear Data

YELLOW Course



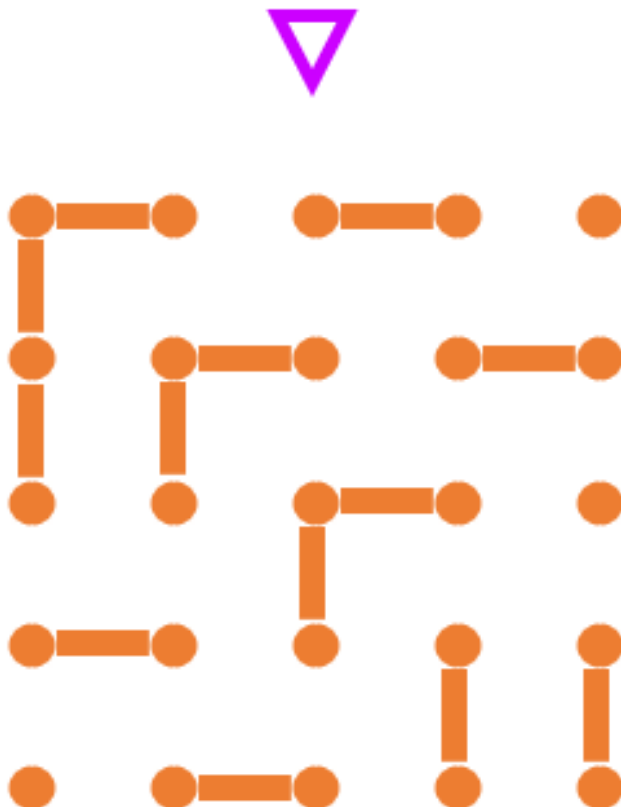

MAZE-02



1. 2 S, 2 E
2. 1 NW, 3 W
3. 2 SE
4. 1 S, 2 W
5. 3 E, 1 SW
6. 1 E
7. 2 N
8. 2 N, 1 SE, 2 S

Finish: 1 N, 1 E

	START--
1	CC--106
2	CC--111
3	CC--118
4	CC--125
5	CC--103
6	CC--104
7	CC--117
8	CC--121
	FINISH-

Maze-Orienteering

A race against the clock!
www.scoutOchallenge.com

Start at the Triangle, find the piece of the map below that shows your current location and the next control, then get there as quickly as you can until you visit all controls.

Do NOT step over/under the maze walls (tape/rope)

1. Clear your scanner data
2. Scan your course selection
3. Scan at START TRIANGLE to start timer
4. **Run the course!**
5. Scan at FINISH sign to stop timer
6. Turn in your scanner to record your score/time



Clear Data

ORANGE Course



MAZE - 03

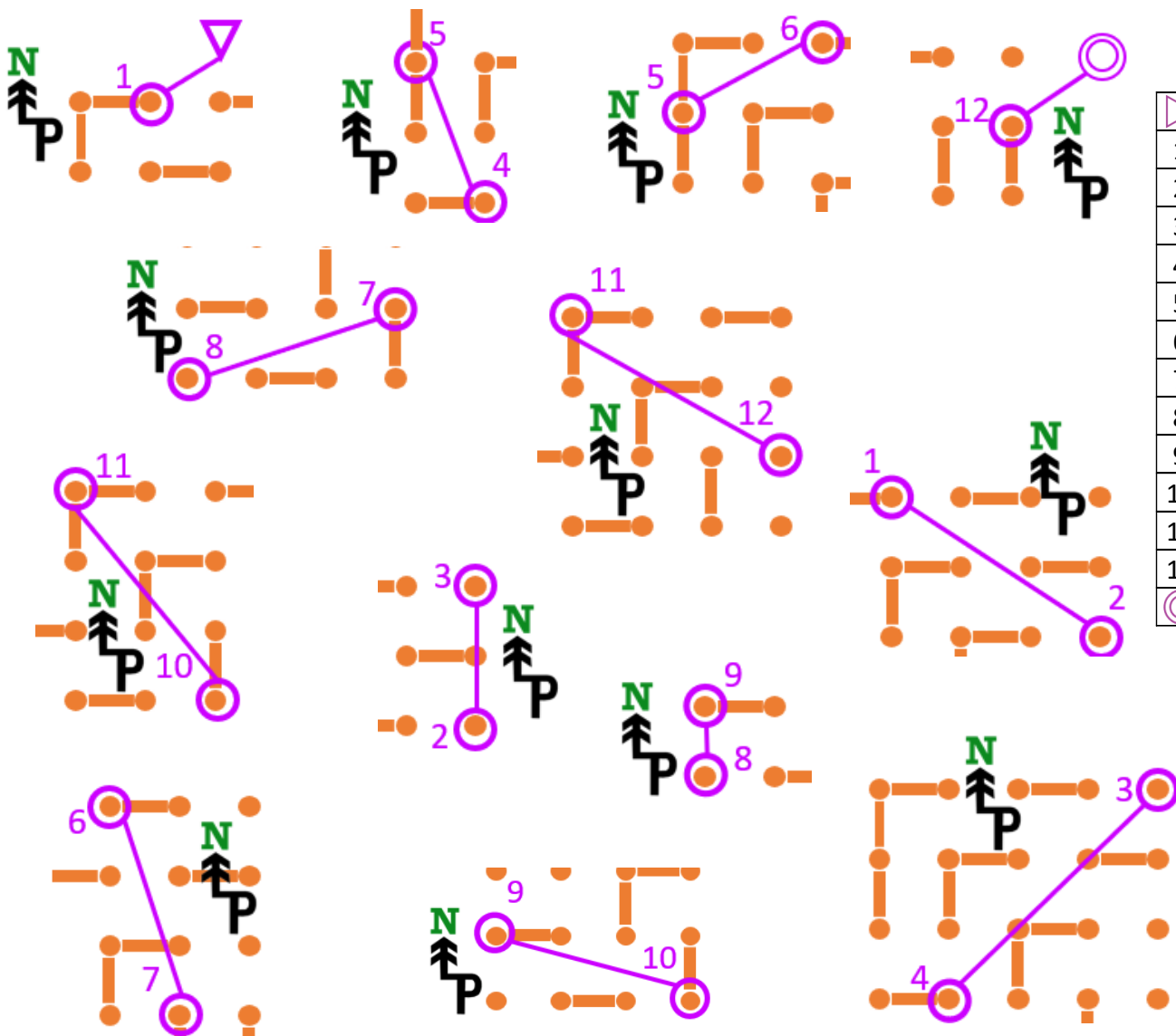

▶	START--
1	CC--112
2	CC--116
3	CC--115
4	CC--124
5	CC--110
6	CC--113
7	CC--122
8	CC--101
9	CC--125
10	CC--104
11	CC--109
12	CC--121
⊙	FINISH-

Maze-Orienteering

A race against the clock!
www.scoutOchallenge.com

Start at the Triangle, find the piece of the map below that shows your current location and the next control, then get there as quickly as you can until you visit all controls. Be careful to orientent each piece to North.

Do NOT step over/under the maze walls (tape/rope)



Clear Data

1. Clear your scanner data
2. Scan your course selection
3. Scan at START TRIANGLE to start timer
- 4. Run the course!**
5. Scan at FINISH sign to stop timer
6. Turn in your scanner to record your score/time

GREEN Course



MAZE-04

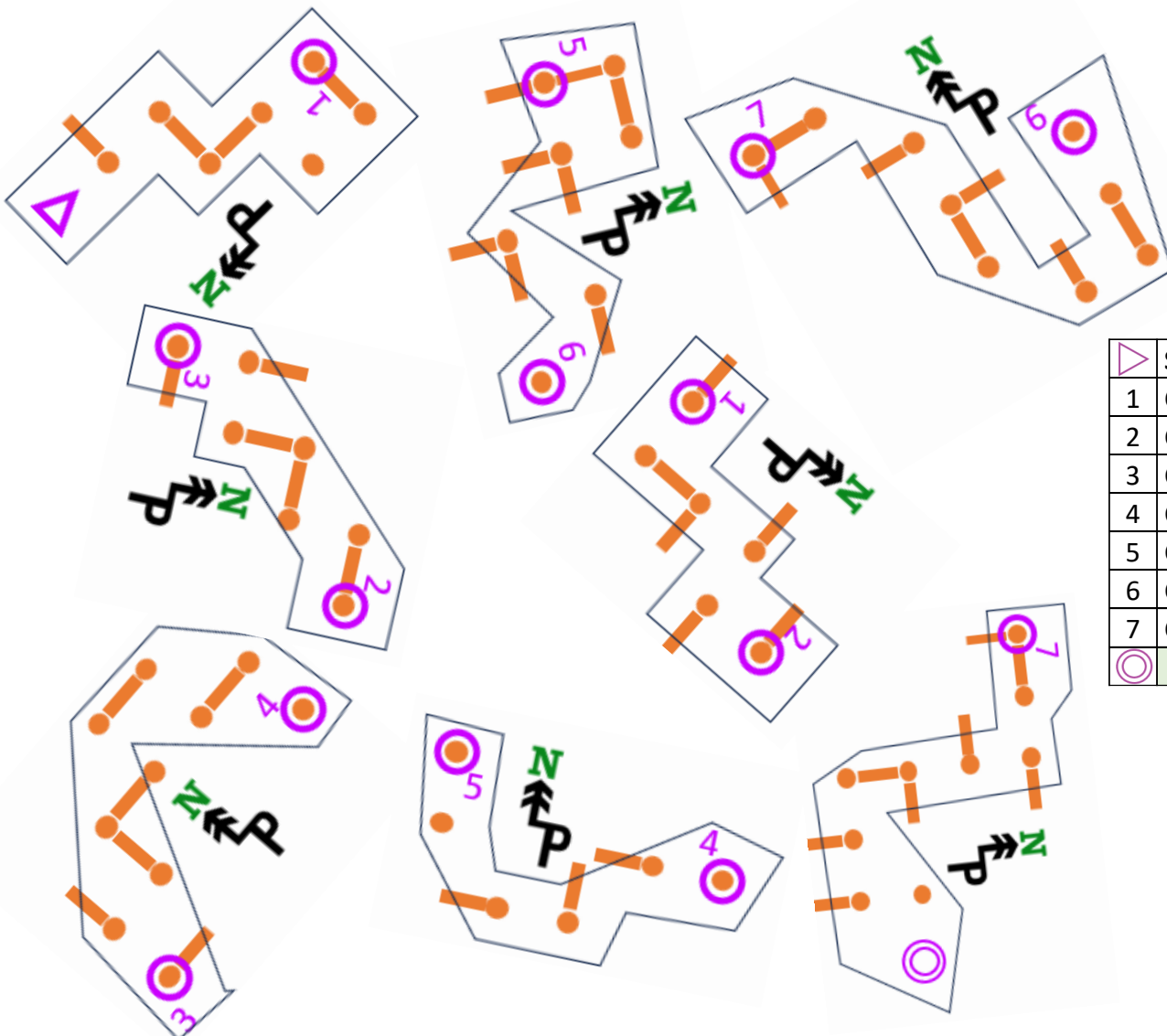

	START--
1	CC--124
2	CC--114
3	CC--125
4	CC--116
5	CC--110
6	CC--116
7	CC--111
	FINISH-

Maze-Orienteering

A race against the clock!

www.scoutOchallenge.com

APPENDIX



























Maze-Orienteering

A race against the clock!

www.scoutOchallenge.com

Control Point Markers

Cut out and attach to each control point, runners either write down the letter code or scan the barcode to record that they made it to the correct control

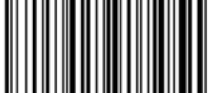
 CC--101 Code: D	 CC--102 Code: F	 CC--103 Code: E	 CC--104 Code: R
 CC--105 Code: T	 CC--106 Code: Q	 CC--107 Code: M	 CC--108 Code: X
 CC--109 Code: Z	 CC--110 Code: C	 CC--111 Code: N	 CC--112 Code: B
 CC--113 Code: W	 CC--114 Code: A	 CC--115 Code: H	 CC--116 Code: K
 CC--117 Code: U	 CC--118 Code: G	 CC--119 Code: L	 CC--120 Code: P
 CC--121 Code: J	 CC--122 Code: V	 CC--123 Code: I	 CC--124 Code: Y
 CC--125 Code: S	 START--	 FINISH-	

Maze-Orienteering

A race against the clock!
www.scoutOchallenge.com

Yellow Course 006 to 021 (this is what the course would look like if the path of the Cardinal Points were drawn on the map)

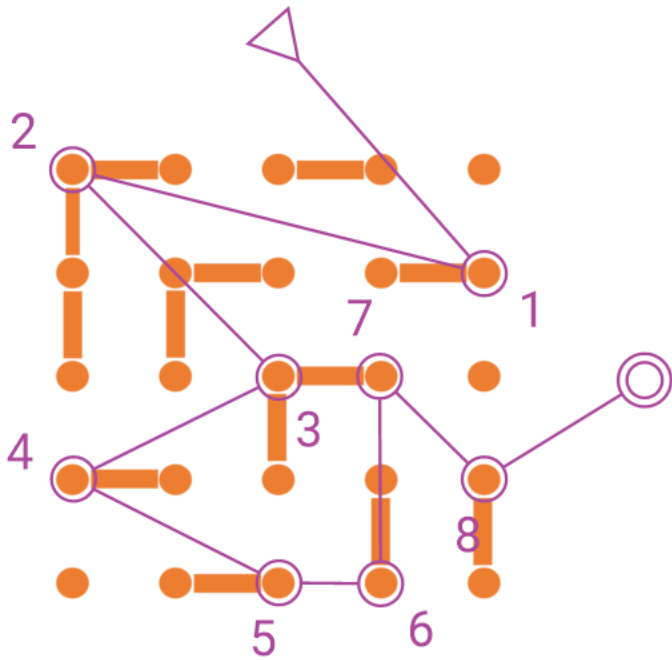

Orange Course 012 to 021 (this is what the course looks like before it is broken into squares)

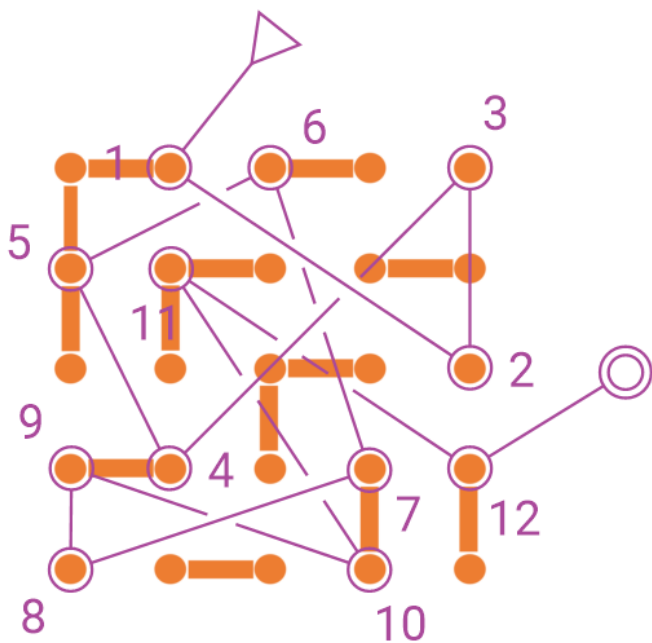

Maze-Orienteering

A race against the clock!
www.scoutOchallenge.com

Green Course 024 to 011 (this is what the course looks like before it is broken into pieces and rotated)

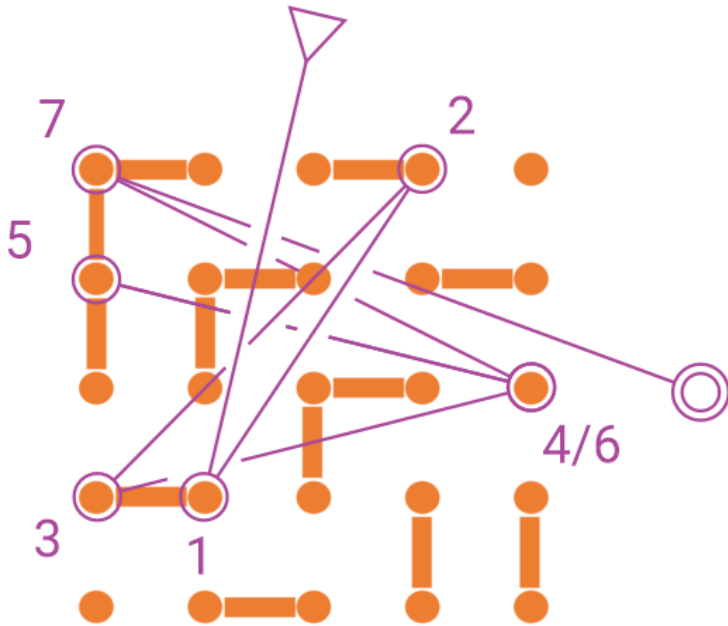

Maze-Orienteering

A race against the clock!
www.scoutOchallenge.com

Blank Cards for events using hand written codes (without punches or barcodes)
Runners write the code they find at the corresponding control point.

Course:					
1	2	3	4	5	6
7	8	9	10	11	12

Course:					
1	2	3	4	5	6
7	8	9	10	11	12

Course:					
1	2	3	4	5	6
7	8	9	10	11	12

Course:					
1	2	3	4	5	6
7	8	9	10	11	12

Course:					
1	2	3	4	5	6
7	8	9	10	11	12

Maze-Orienteering

A race against the clock!
www.scoutOchallenge.com

Answer Keys

Course:		White – Answer Key									
1	L	2	S	3	F	4	T	5	J	6	X
7	A	8		9		10		11		12	

Course:		Yellow – Answer Key									
1	Q	2	N	3	G	4	S	5	E	6	R
7	U	8	J	9		10		11		12	

Course:		Orange – Answer Key									
1	B	2	K	3	H	4	Y	5	C	6	W
7	V	8	D	9	S	10	R	11	Z	12	J

Course:		Green – Answer Key									
1	Y	2	A	3	S	4	K	5	C	6	K
7	N	8		9		10		11		12	

Maze-Orienteeing

A race against the clock!

www.scoutOchallenge.com



Please let us know if you liked this activity! Feedback is collected at:

<https://www.centraltexasspringo.org/maze-o/>

For more Orienteering fun, check your local Orienteering Club.

In Central Texas it's Austin Orienteering Club



www.AustinOC.com

The annual Spring-O in Central Texas is a huge orienteering event with special activities focused on Scouts. www.CentralTexasSpringO.org

Maze-Orienteering

A race against the clock!

www.scoutOchallenge.com

Revision Notes:

Revision	Date	Change Description	Editor
Rev 1	6/1/2024	Original release	KA
Rev 2	8/16/2024	<ul style="list-style-type: none">• Reduce recommended grid spacing to 10ft• Change control code to 3 digit numbers to be more consistent with other Spring-O courses• Update barcodes for more reliable scanning (Code-128 and minimum 7 characters)• Add punch card template	KA